

**4.75 IN./120.65MM  
 TORPEDO DIA.**

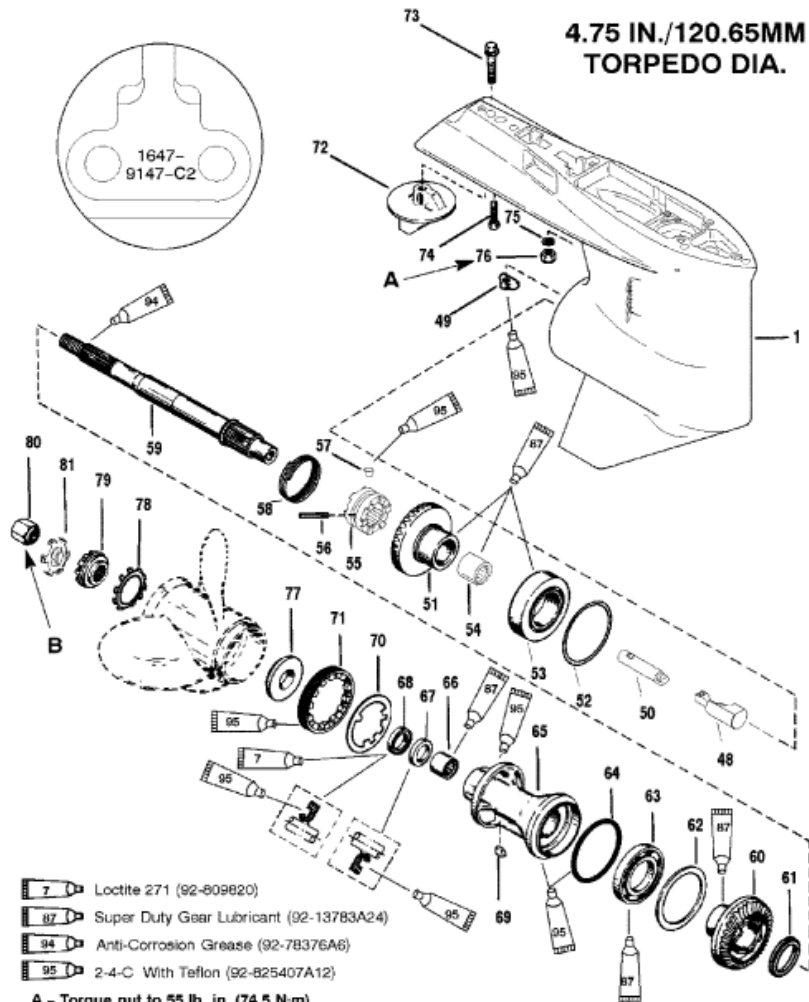

- Loctite 271 (92-809820)
- Super Duty Gear Lubricant (92-13783A24)
- Anti-Corrosion Grease (92-78376A6)
- 2-4-C With Teflon (92-825407A12)

**A - Torque nut to 55 lb. in. (74.5 N-m)**  
**B - Torque propeller nut to 55 lb. ft. (74.5 N-m)**

11979

**Parts List**

Ref	Class	Part	Description	Qty	Comment	Footnote
1	1647	9148A93	GEAR HOUSING	1	(Black) (Basic)	
1	1647	9148A94	GEAR HOUSING	1	(Gray) (Basic)	
48		89594A 1	FOLLOWER	1		
49		78956 2	SHIFT CAM	1		
50		828287	ROD	1		
51	43	828174A 2	GEAR SET	1	[XR6/Magnum III/175/200] (1.87:	
51	43	828176A 2	FORWARD GEAR	1	(135/150) (2.0:1 - 14/28)	
52	15	44491A 1	SHIM SET (.006-7-9-10-20)	AR		9
53	31	30894A 1	BEARING SET, Cup And Cone	1		
54	31	30895	BEARING, Needle	1		
55	52	828288	SLIDING CLUTCH	1		
56	17	30632	PIN, Cross	1		
57	17	828356	PIN, Detent	1		
58	24	30893	SPRING	1		
59	44	94148	PROPELLER SHAFT	1		
60	43	828175A 1	REVERSE GEAR, (15/28)	1	[XR6/Magnum III/175/200]	
60	43	828177A 1	REVERSE GEAR, (14/28)	1	(135/150)	
61	23	824108	SPACER	1		
62		68100 1	RING, Thrust	1		
63	30	88957	BEARING ASSEMBLY, Ball	1		
64	25	31534	O-RING	1		4,8
65		43567A 1	BEARING CARRIER ASSEMBLY	1		
66	31	30956	BEARING, Needle	1		
67	26	14077	SEAL, Oil, Inside	1		
68	26	76868	SEAL, Outside	1		8
69	28	30281	KEY	1		
70	14	79447	TAB WASHER	1		
71		79448	RETAINER	1		
72		31640 5	TRIM TAB	1		
72		76214A 5	TRIM PLATE	1	(Tracker)	
73	10	806327	SCREW, (.437-14 x 1.750)	1		
74	10	65210	SCREW, (.375-16 x 1.00)	1		
75	12	45176	WASHER, (.453 x .812 x .105)	2	(These Replacement Parts Are No	
76	11	34933	NUT, (.437-20)	2	(These Replacement Parts Are No	
77	12	835467 1	THRUST HUB	1	(These Replacement Parts Are No	5
78	13	42351 1	LOCKWASHER, Toothed	1	(These Replacement Parts Are No	
79	12	31211A 2	WASHER, Splined	1	(These Replacement Parts Are No	
80	11	52707A 1	NUT KIT, Propeller	1	(These Replacement Parts Are No	
81	14	816629	TAB WASHER	1	(These Replacement Parts Are No	
-	27	815791A92	ENGINE GASKET SET	1		
-	26	89228A 2	SEAL KIT	1		